

THIS DOCUMENT CONTAINS DATA PROPRIETARY TO PROJECTS UNLIMITED, INC. ANY USE OR REPRODUCTION, IN ANY FORM, WITHOUT PRIOR WRITTEN PERMISSION OF PROJECTS UNLIMITED, INC. IS PROHIBITED.
 © 2005, Projects Unlimited Inc.

SPECIFICATIONS

PARAMETERS	VALUES	UNITS
RATED VOLTAGE	24	Vdc
OPERATING VOLTAGE RANGE	10-28	Vdc
TONE OUTPUT	SEE 32 TONE CHART	-
RATED CURRENT	SEE 32 TONE CHART	mA
INGRESS PROTECTION	IP54	-
COLOR	WHITE	-
OPERATING TEMPERATURE	-25 ~ +70	°C
HOUSING MATERIAL	ABS	-
TERMINAL MATERIAL	SCREW	-
WEIGHT	150	grams

DETAIL "A"

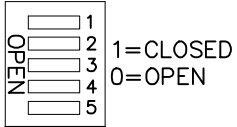

DETAIL "B"

VOLUME CONTROL



OPTIONAL COVER
AWA-05CWC

NOTES:

- ALL DIMENSIONS ARE IN MILLIMETERS.
- SPECIFICATION SUBJECT TO CHANGE OR WITHDRAWAL WITHOUT NOTICE.
- THIS PART IS RoHS 2002/95/EC COMPLIANT.

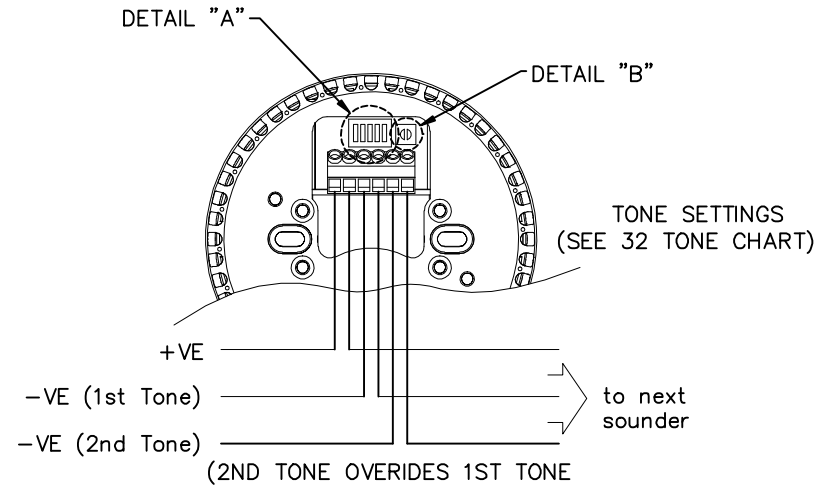
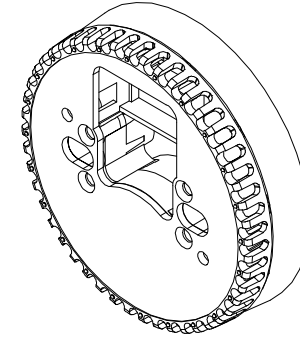
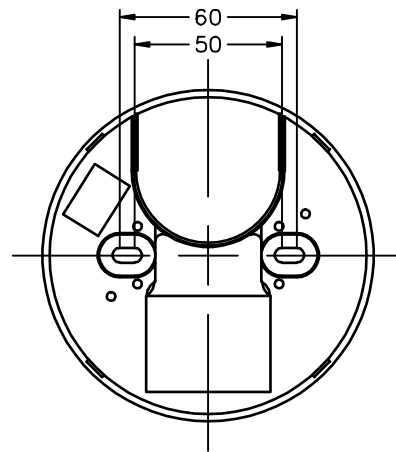
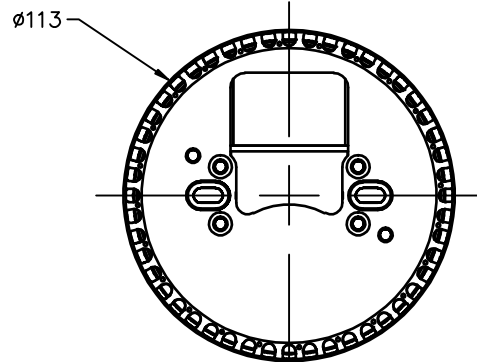

REVISIONS			
LTR	DESCRIPTION	DATE	APPROVED
-	RELEASED FROM ENGINEERING	12/7/05	
A	ADDED RoHS & COVER NOTES	5/21/07	R.W.

UNLESS OTHERWISE SPECIFIED: DIMENSIONS ARE IN MILLIMETERS, TOLERANCES ARE ±0.5 AND ANGLES ARE ±3°.		 projects® unlimited Dayton, Ohio									
<table border="1"> <thead> <tr> <th>APPROVALS</th> <th>DATE</th> </tr> </thead> <tbody> <tr> <td>DRAWN <i>J.A.F.</i></td> <td>12/05</td> </tr> <tr> <td>CHECKED <i>E.P.</i></td> <td>12/05</td> </tr> <tr> <td>APPROVED <i>B.R.</i></td> <td>12/05</td> </tr> </tbody> </table>		APPROVALS	DATE	DRAWN <i>J.A.F.</i>	12/05	CHECKED <i>E.P.</i>	12/05	APPROVED <i>B.R.</i>	12/05	SIREN	
APPROVALS	DATE										
DRAWN <i>J.A.F.</i>	12/05										
CHECKED <i>E.P.</i>	12/05										
APPROVED <i>B.R.</i>	12/05										
<table border="1"> <thead> <tr> <th>SIZE</th> <th>DRAWING NO.</th> </tr> </thead> <tbody> <tr> <td>A</td> <td>AW-05CW-NC</td> </tr> </tbody> </table>		SIZE	DRAWING NO.	A	AW-05CW-NC						
SIZE	DRAWING NO.										
A	AW-05CW-NC										
DO NOT SCALE DRAWING		SCALE: N.T.S.	SHEET 1 OF 1								

FILE NAME
AW-05CW-NC.DWG

Primary tone	Secondary tone	Switch setting	Tone description				Main Application	AW-05C					
			12345	Pattern	Frequency Hz	Rate		Depiction	12 VDC	12 Vdc on axis @1M	24 VDC	24Vdc on axis @1M	EN54-3 28Vdc see notes
									mA	dB(A)	mA	dB(A)	dB(A)
1	14	11111	Alternating	800 & 970	2Hz (250ms-250ms)		BS Fire tone	10	87	18	93	*	
2	14	11110	Sweep	800 to 970	7Hz (7/s)		BS Fire tone	10	87	18	93	*	
3	36	11101	Sweep	800 to 970	1Hz (1/s)		BS Fire tone	10	87	18	93	86	
4	14	11100	Continuous	2850	Steady			16	96	32	102	*	
5	4	11011	Sweep	2400 to 2850	7Hz			18	97	30	102	*	
6	4	11010	Sweep	2400 to 2850	1Hz			17	97	30	102	*	
7	14	11001	Slow whoop	300 to 1200	3s sweep, 0.5 s silence, then repeat		Dutch Fire tone	12	87	20	91	88	
8	14	11000	Sweep (DIN)	1200 to 500	1Hz		Din tone	9	87	16	91	87	
9	4	10111	Alternating	2400 & 2850	2Hz (250ms-250ms)			19	95	30	101	*	
10	14	10110	Intermittent	970	0.5Hz (1s On/1s Off)			9	86	12	91	*	
11	14	10101	Alternating	800 & 970	1Hz (500ms-500ms)		BS Fire tone	10	87	18	92	*	
12	4	10100	Intermittent	2850	0.5Hz (1s On/1s Off)			14	94	24	98	*	
13	14	10011	Intermittent	970	0.8Hz (250ms On/1s Off)			5	82	8	87	*	
14	14	10010	Continuous	970	Steady		BS Fire tone	11	87	20	92	82	
15	14	10001	Alternating	554 & 440	100ms-400ms		French fire tone	7	83	12	87	*	
16	16	10000	Intermittent	660	3.3Hz (150ms On/150msOff)		Swedish fire tone	6	85	9	88	*	
17	17	01111	Intermittent	660	0.28Hz(1.8s On/1.8s Off)		Swedish fire tone	7	87	12	92	*	
18	18	01110	Intermittent	660	0.05Hz (13s Off / 6.5Hz On)		Swedish fire tone	8	88	14	93	*	
19	19	01101	Continuous	660	Steady		Swedish fire tone	8	88	14	93	*	
20	20	01100	Alternating	554 & 440	0.5Hz (1s On/1s Off)		Swedish fire tone	7	84	13	90	*	
21	21	01011	Intermittent	660	1Hz (500ms-500ms)		Swedish fire tone	6	83	10	90	*	
22	14	01010	Intermittent	2850	4Hz (150ms On/100ms Off)		Pelican crossing	13	92	22	98	*	
23	14	01001	Sweep	800 to 970	50Hz		BS Fire tone	10	87	18	92	*	
24	4	01000	Sweep	2400 to 2850	50Hz			14	97	25	102	*	
25	25	00111	Intermittent	970	3 x 500ms pulses followed by 1.5s silence then repeat		ISO 8201	9	82	14	88	*	
26	26	00110	Intermittent	2850	3 x 500ms pulses followed by 1.5s silence then repeat		ISO 8201	12	91	20	97	*	
27	27	00101	Continuous	4000	Steady			18	90	35	98	*	
28	10	00100	Alternating	800 & 970	2Hz (250ms-250ms)		BS Fire tone	10	87	17	92	*	
29	33	00011	Alternating	990 & 650	2Hz (250ms-250ms) (Symphoni tones)		BS Fire tone	10	86	18	92	86	
30	36	00010	Alternating	510 & 610	2Hz (250ms-250ms) (Squashni Micro tones)		BS Fire tone	8	83	13	90	85	
31	31	00001	Sweep	300 to 1200	1Hz			12	87	20	91	*	
32	32	00000	Continuous	4000	Steady			18	90	35	98	*	

Note (a): Tones approved under the Construction Products Directive for Fire Alarm Applications, are shown in the column marked EN54-3.

Note (b): EN54-3 measurements shown reflect minimum expected SPL readings at Maximum Volume at the Loudest Point around the EN54-3 defined sounder axis.

Note (c): All other tone measurements reflect manufacturers data based on 'on axis' measurements, and are not verified by a Notified body.

Note (d): All measurements taken at 20°C operating temperature.